



*Excel Solutions, Inc.
315 Ken Mar Industrial Pkwy
Broadview Heights, OH 44147
1-855-951-4499
www.excelolutions.com*

Foam Dock Seal With Fixed Head Pad

All Models

Installation Instructions



Do not install this product unless you read and understand the Warnings and Installation Instructions contained in this manual. Failure to do so could result in serious injury or death.

FOAM DOCK SEAL

Installation Instructions

CHECK FIRST:

To ensure proper measurement to accommodate the Dock Seal you are installing, check the following:

A. Check the door height and width to verify that your side pads and head pad are properly sized.

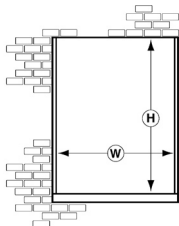

B. It is recommended that the head pad or side pads be compressed not more than a maximum of 6"; nor more than 45% of its total projection. A minimum of 4" compression is advised to compensate for vehicles not evenly spotted against the building.

C. If the approach is not level, check to make sure the side pads taper to accommodate the angle of the truck. Also on a tapered drive, follow Step "B" for both the top and bottom of the seal, allowing for the recommended compression.

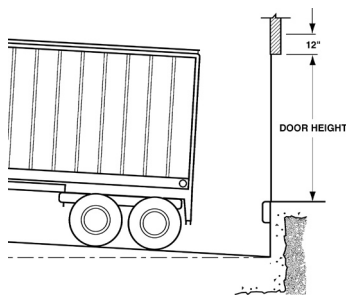

D. Check the heights of incoming carriers that will be utilized at this door, to ensure that the head pad is of proper elevation to accommodate the height range of these vehicles.

E. In 95% of installations, the inside edge of the face of the side pads should be 7'-6" I.D. If achieving the 7'-6" dimension requires extending the wood backing of the side pads into the door opening width, use the following recommendation:

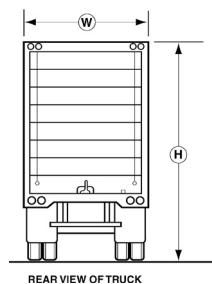

Weld or anchor a structural angle the full length of the side jambs, not allowing any portion of the wood backing to be exposed into the door opening. It is appropriate to lag through the leg of the angle into the back of the wood approximately 1" from the edge of the board.

⚠ WARNING

Improper lifting or attachment of seal/shelter can cause serious injury or death.

Installation requires:

- A structurally sound building wall,
- Barricades to keep people away from the area,
- Proper attachment of anchoring devices,
- Two or more people,
- A lifting device capable of lifting at least 500 lbs. at the installation angle.

If you have questions, contact your supervisor or Excel Solutions at 1-855-951-4499.

INSTALLATION:

1. There are two types of recommended installation; one being the head pad mounted above the side pads, the other being the head pad mounted between the side pads. Before proceeding with installation, verify which of the two types you have.

2. Mark the center of the door opening on the dock floor.

3. From this center point, measure 3'-9" in each direction to determine the position of the side pads. This should give you your 7'-6" I.D. (See Step "E").

4. If the side pads are flush with the door jamb, all standard mounting hardware can be utilized, which is normally: (2) 3/32"x3"x5" flat mounting brackets per pad and (2) 3/32"x3"x1-1/2"x3-1/2" angle mounting brackets per pad.

The flat brackets are secured by means of welding or anchoring into the doorjamb allowing precisely 1-7/16" projecting away from the jamb. The flat bracket should be mounted with the slotted end against the jamb, and the end with two holes extending 1-7/16" away from the jamb. If the side pads are not flush with the doorjamb, install angle brackets by following Step 6, and complete the jamb installation by following Step "E".

5. After the jamb brackets have been installed, mount (2) of the angle brackets on the outside of the side pads. NOTE: There are right and left side pads. To distinguish between the two, the air pockets are to be on the outside of the pad, pointing down.

6. With the appropriate side pad, predrill and mount two of the angle brackets 1'-6" from each end, using the lag screws provided. The brackets should be mounted so the slotted leg will mount against the building face. When installing the angle brackets be sure to keep the slotted leg flush with the back of the seal.

7. With the angle brackets installed, hold pad in place against the premounted jamb brackets, then predrill into the wood backing and lag secure. Mount onto the face of the building through the slot with appropriate anchors.

8. With the side pads in place, mount the head pad following the same procedures, except the air pockets point down into the opening and the head jamb brackets are mounted 1'-0" in from each end of the side jamb.

9. Caulk and fill all voids. Clean pads and hardware as required. Clear the dock area of any debris resulting from installation procedure.

SUGGESTED MOUNTING METHODS:

(Mounting anchors not included.)

Concrete or Brick Wall: Try to hit mortar joints. Use 1/2" or 3/8" x 3" expansion anchors. use through-bolt fastening if anchors will not hold, 3/8" threaded rod is recommended.

Precast Concrete: Same as above.

Metal Skin Building: Through-bolt fastening as above. Use a back-up plate (steel or wood) to support bolts or anchor through existing building horizontal and vertical structural members when possible.

NOTE: Dock Seals must have adequate bumper protection, 4" minimum.

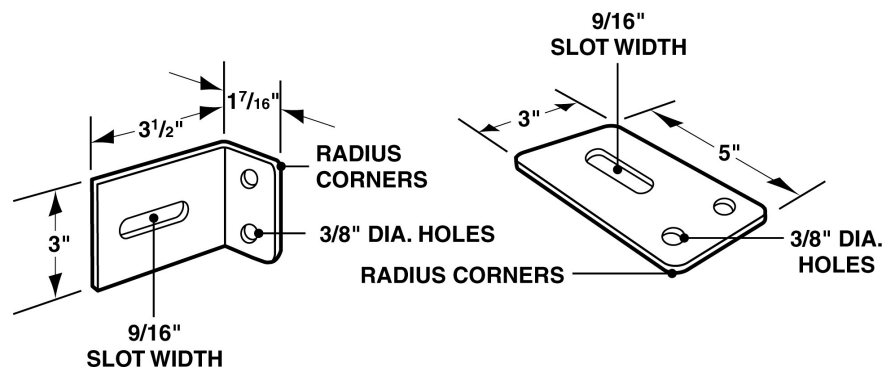
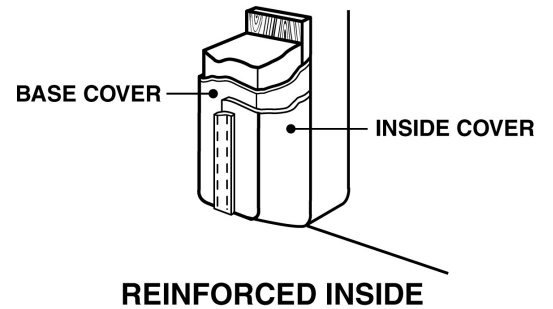
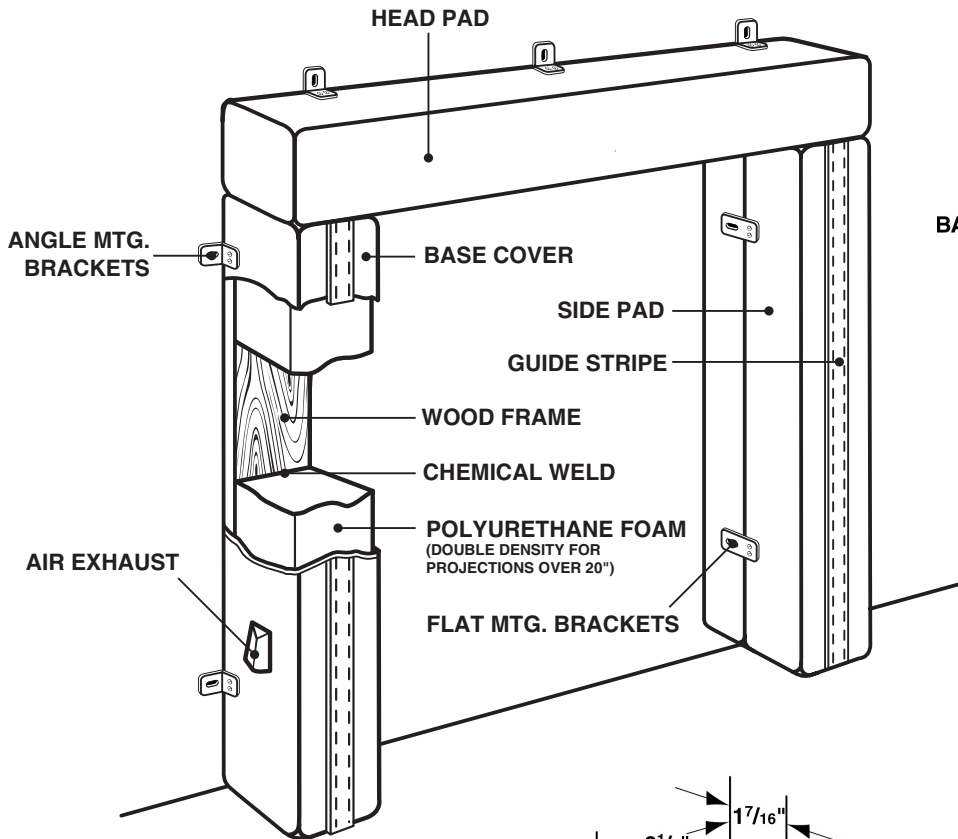
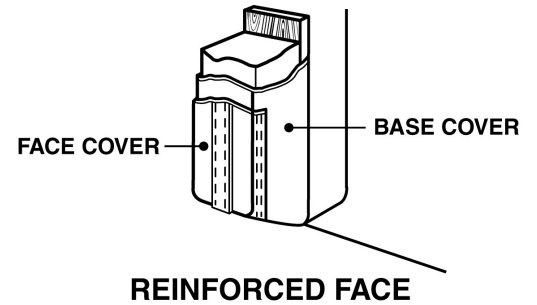

ANGLE AND FLAT MOUNTING BRACKETS

OPTIONAL WEAR PLEAT:

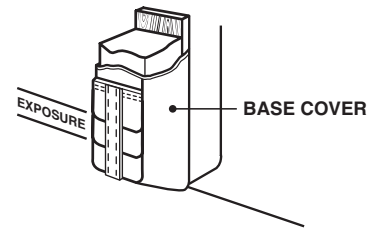
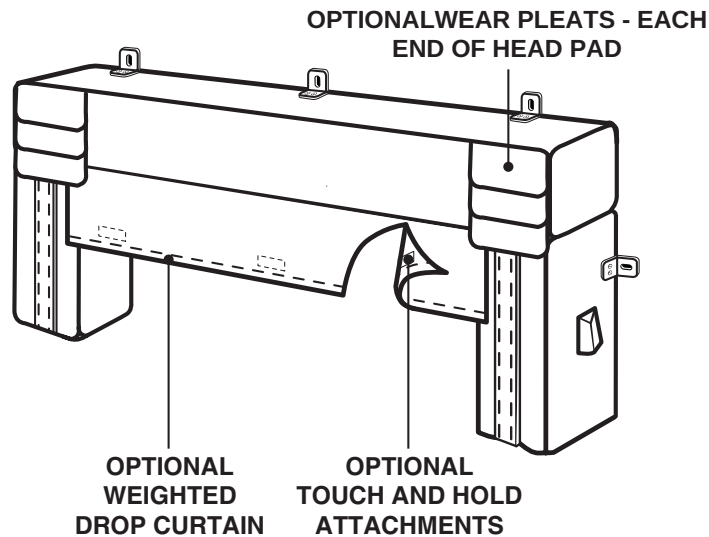

WEAR PLEATS

- 4" EXPOSURE
- 8" EXPOSURE
- 16" EXPOSURE

LIMITED PRODUCT WARRANTY

GENERAL

EXCEL SOLUTIONS INC. EXTENDS THIS LIMITED WARRANTY TO THE ORIGINAL BUYER AND WARRANTS THAT ALL PRODUCTS MANUFACTURED BY EXCEL SHALL BE FREE FROM ORIGINAL DEFECTS IN WORKMANSHIP AND MATERIALS FOR ONE YEAR FROM DATE OF SHIPMENT, PROVIDED SAME HAVE BEEN PROPERLY SIZED FOR THE APPLICATION, STORED, INSTALLED, SERVICED, MAINTAINED AND OPERATED. THIS WARRANTY SHALL NOT APPLY TO PRODUCTS WHICH HAVE BEEN ALTERED OR REPAIRED IN ANY WAY SO AS, IN EXCEL'S JUDGMENT, AFFECTS ITS PERFORMANCE OR RELIABILITY, NOR WHICH HAVE BEEN IMPROPERLY INSTALLED OR SUBJECTED TO MISUSE, NEGLIGENCE, OR ACCIDENT, OR INCORRECTLY USED IN COMBINATION WITH OTHER SUBSTANCES. COMPENSATION FOR PRODUCTS HAVING WEAR AND TEAR CAUSED BY NORMAL USAGE IS NOT PROVIDED FOR BY THIS WARRANTY.